



The Belmont





Windows to Improve Your Lifestyle

The Belmont series from Alliance Window Systems® offers the features and benefits usually found only on the most expensive windows ... at an exceptional value. Created with meticulous engineering and efficient manufacturing technology, the Belmont series makes replacing those old drafty windows an easy choice.

Remodeling your home? Your options are open with the Belmont series. Select from double- or single-hung, twin- or single-vent slider, picture windows or casements. No matter what your home's styling and décor, Alliance Window Systems® Belmont series has a style that will harmonize beautifully.

With Belmont, you receive beauty and function. Your windows will be thermally efficient, and easy to clean and operate. Designed with a balance system that never needs adjustment, our windows are maintenance free. And, they are backed by one of the industry's strongest warranties – our exclusive Assurance Plus® warranty.

The Belmont:



Double-Hung Features

- Double strength glass is standard.
- Three layers of weather stripping is standard on all sashes.
- Non-corrosive hardware includes a lifetime of trouble-free performance.
- Cam lock action draws sashes closer together for positive lock.
- Additional security provided by an interlocking meeting rail.

Beauty & Function

Anatomy of Efficiency

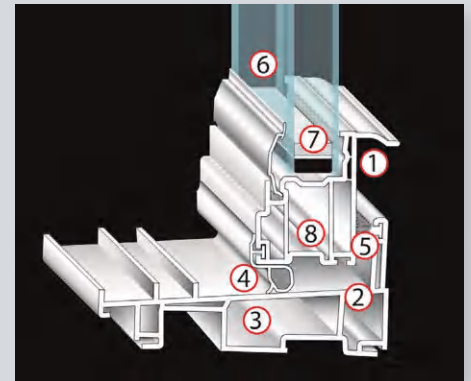

Energy efficient Belmont windows provide an effective barrier to any weather condition.

- (1) Dual hollows at lift rail add strength and insulation
- (2) Heavy walled PVC framing acts as a natural insulator
- (3) Dead air spaces within the frame and sash profiles further resist energy flow
- (4) Closed cell compression seal at sloped sill resists air and water penetration
- (5) Fin seal weather stripping at sill reduces air infiltration even more
- (6) 3/4" Insulating glass provides optimal energy efficiency
- (7) "Warm edge" low conductance spacer resists energy flow through the edge of glass
- (8) Water management grooves channel moisture away from insulated glass sealant

Double-Hung Features

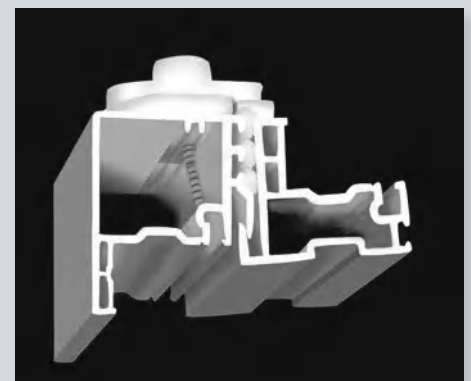



Slider Features

- Two sets of double-wheeled brass rollers transfer weight of glass directly to frame reducing stress on sash members
- Rollers glide on integral track system allowing for effortless fingertip operation
- Both sashes lift out for easy cleaning
- Independent weep chambers on frame assure effective water run-off

Casement Features

- Sash opens completely, so windows can be cleaned easily from inside your home
- All components are corrosion resistant, providing years of trouble-free performance
- Multi-Point Locking System locks sash at multiple points – for utmost security
- Three layers of weather stripping assure effective barrier to air and water penetration
- Top rated hardware system allows even the largest casements to be effortlessly and smoothly operated



Casement Profile



(1) Multi-point lock

(2) Heavy-wall reinforced construction: Allows for slim-line look while insuring maximum strength and durability

(3) Low profile curved lock: Lies flat, out of the way of window treatments

(4) Low torque operator: Crank requires 33% less operating force; fold-down handle available



The Belmont has a unique profile sash and narrow frame to allow maximum exposed glass area.

*You'll love our windows for all of the things
they bring into your home –
and for all the things they keep out.*

Single-Hung



Single Slider



Single-Hung and Single Slider Features

- Double strength glass is standard.
- Three layers of weather stripping is standard on all sashes.
- Full lift rails for ease of operation.

Exterior & Interior Colors*

You'll appreciate the many colors available in our Belmont series. Customers can choose from 18 standard mix and match combinations available from our exterior color and interior color selections. We'll custom match any exterior color too!

Exterior color options are available on all Alliance Window Systems® products. When grids are ordered, the color will be made to match the exterior frame color.

*Note: Colors and stains shown are printed representations. Contact your Alliance Window Systems® dealer to view actual samples.

Standard Interior Colors



Standard Exterior Colors



Spacer Performance

Duralite® spacers are the best spacers in comparison testing with other commonly used insulated glass systems. Duralite® spacers yield a lower window U-value – up to 0.03 over other less efficient systems. And that means more comfort and energy savings for you.

Condensation Resistance: No spacer system can eliminate condensation, but Duralite® reduces conductivity by 50% over other warm edge spacers. Reducing conductivity also reduces condensation.

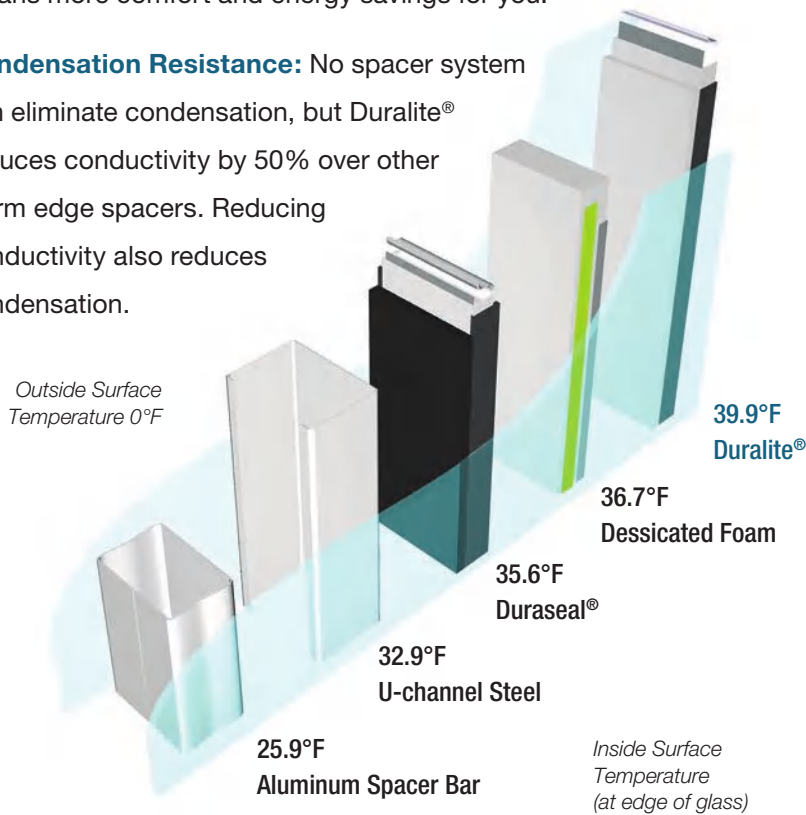

The Belmont: A Remarkable Window

Product	U Value	Solar Heat Gain Coefficient	Air Infiltration
Belmont Single-Hung			
– InnovativE® Glass Package*	0.27	0.29	0.10
Belmont Double-Hung			
– InnovativE® Glass Package*	0.27	0.28	0.12
Belmont Casement			
– InnovativE® Glass Package*	0.27	0.27	0.03
Belmont Twin Vent Slider			
– InnovativE® Glass Package*	0.27	0.28	0.16
Belmont Single Vent Slider			
– InnovativE® Glass Package*	0.27	0.29	0.09

*The InnovativE® Glass Package comes standard with double strength glass, Low E coating, Duralite® spacer and Argon gas fill.

Easy Operation and Cleaning



Window cleaning is simplified with tilt-in upper and lower sashes.

Options

Choices include standard and custom pattern grids in your choice of flat, contour or pencil muntin bars that fit securely within the insulating glass air space.

Other options include upgrade Low E coatings, tinted and obscure glass, choice of nine exterior colors available with white or tan interior finishes.





Our Lifetime Warranty

Alliance is not just our name. It also accurately describes our approach to doing business, and it's why we can provide such an exceptional warranty on every window we offer for your consideration. A proud, independent regional fabricator of excellent experience and reputation meticulously crafts each of our windows. By linking these carefully selected and exceptional fabricators into a national network, or alliance, we are able to be so confident of the quality that is designed and built into our windows, we can back our entire product line with an unsurpassed warranty.

Of course, other window companies may also say they offer a warranty, but we urge you to carefully read their fine print. They may, for example, guarantee the vinyl extrusion, but what about all the moving parts or the insulated glass? The Alliance Assurance Plus® Limited Lifetime Warranty covers it all – for life! Even more remarkable, if a factory defect needs repair within the first five years, we will even provide the labor required.

Many windows leave you wide open to unpleasant surprises. Select a window from Alliance Window Systems® and you'll know it's backed by a warranty second to none.

Visit midwaywindows.com



Look for the ENERGY STAR label on qualified products.